



TURBAIR® vacuum blower technology

Pioneering energy
efficiency and
sustainability in
paper production

Sustainability meets performance: TURBAIR® vacuum systems in action

The paper and packaging industry is undergoing a transformative shift. As global demand for sustainable production rises, manufacturers are actively seeking technologies that reduce environmental impact without compromising performance. At the heart of this transition is the vacuum system – a critical component in paper production. Everllence's TURBAIR® vacuum blower technology has emerged as a powerful, eco-efficient alternative to conventional vacuum systems, redefining standards for energy consumption, water usage, and CO₂ emissions.

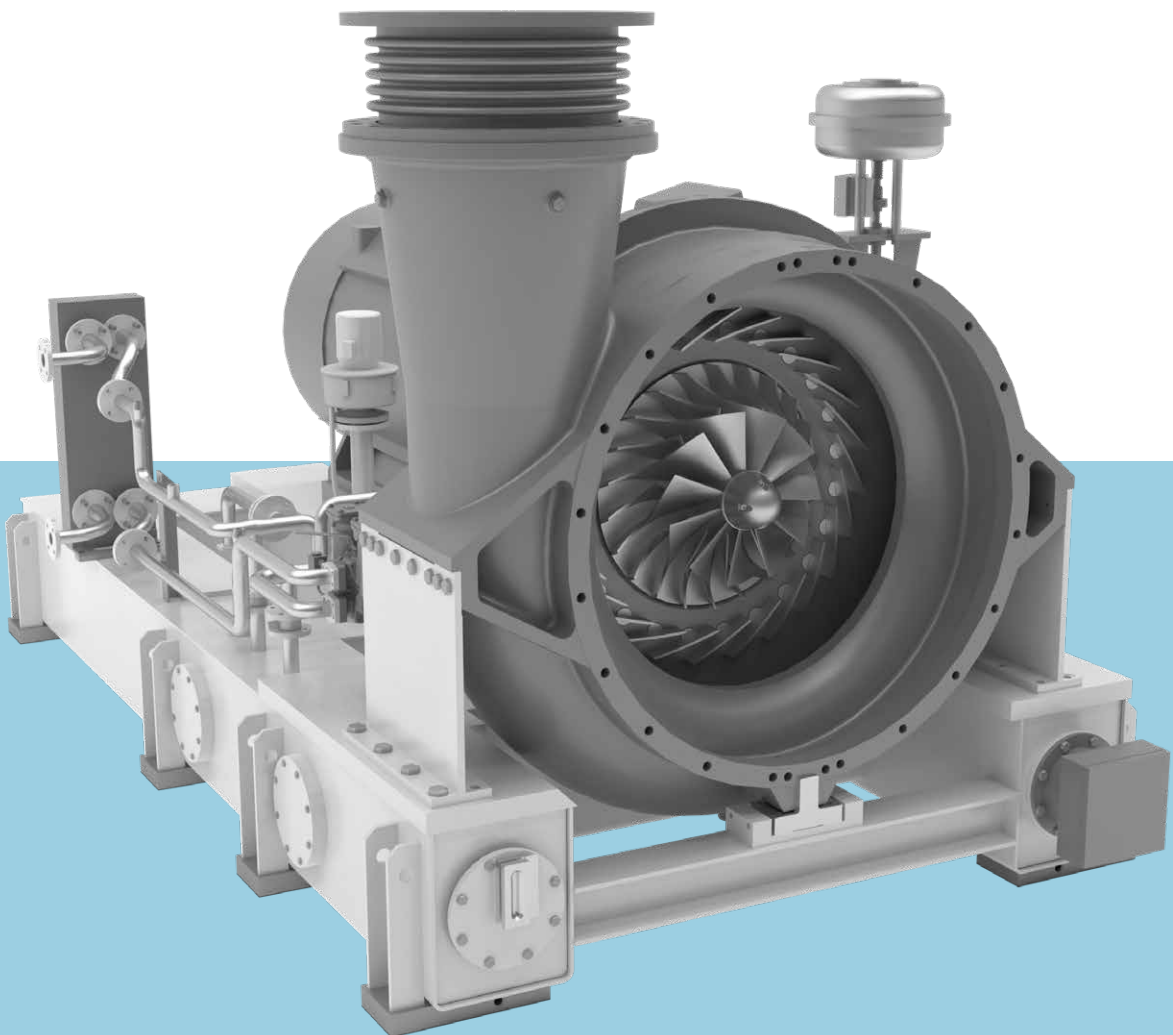

The sustainability challenge in paper manufacturing

Paper machines consume enormous quantities of energy, particularly in the dewatering process. Conventional vacuum systems, such as water ring pumps, contribute significantly to energy and water demand. With increasing regulatory pressure and more ambitious corporate sustainability goals, manufacturers are prioritizing solutions that reduce carbon footprints, cut costs, and support the principles of the circular economy.

Introducing TURBAIR®: the eco-conscious vacuum blower solution

TURBAIR® vacuum blowers are engineered specifically for the challenges of the paper industry. Unlike traditional water ring pumps, TURBAIR® systems operate on dry compression, eliminating the need for sealing water and significantly reducing energy input. Designed for dewatering and felt conditioning across board, tissue, and pulp machines, TURBAIR® sets new benchmarks in operational efficiency and environmental performance.

Key advantages include:

- Up to 60% energy savings compared to water ring pumps
- Up to 99% water savings, minimizing consumption and disposal costs
- Heat recovery potential up to 80% via exhaust pipe heat exchangers
- Significant reductions in CO₂ emissions

Case study: Smurfit-Kappa's investment in TURBAIR® at Cerro Gordo

In early 2024, Everllence was selected by global packaging leader Smurfit-Kappa to supply two TURBAIR® vacuum blowers for its board paper mill in Cerro Gordo, Mexico. The project reflects the company's commitment to innovation and decarbonization.

TURBAIR® will support Smurfit-Kappa in achieving its environmental targets by lowering energy use and water consumption – a strategic move for sustainability and long-term cost efficiency. The deployment marks a significant mile-stone for TURBAIR® in the Latin American market.

Quantifiable benefits of TURBAIR® systems

Benefit	Performance
Energy savings	40–60% vs. water ring pumps
Water savings	Up to 99%
Heat recovery potential	Up to 80%
Reduced CO ₂ emissions	Proportional to energy savings
Operational reliability	Increased uptime, lower maintenance

These metrics have been validated in field installations worldwide, with Smurfit-Kappa's Cerro Gordo facility as a leading example of the achievable benefits.

Voices from the industry: poll insights

To better understand market awareness and perceptions around vacuum technologies, Everllence conducted a LinkedIn poll campaign at the end of 2024. The engagement offered valuable insights:

- **Awareness gap:** A significant portion of respondents were unfamiliar with the environmental challenges and technological options in dewatering.
- **Performance perceptions:** While many were unsure of the exact benefits, a majority correctly estimated that TURBAIR® could offer energy savings in the 40–60% range.
- **Decarbonization focus:** Respondents expressed strong interest in energy recovery and water reduction as primary sustainability levers.



Have you already heard about the special challenges involved in the project with Smurfit-Kappa?

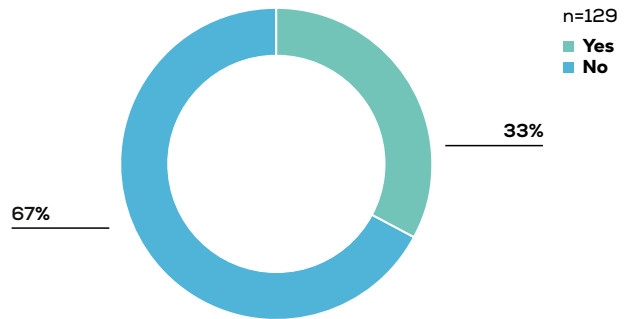

The dewatering of paper mills is an energy-intensive process. Do you know how you can reduce your decarbonization footprint?

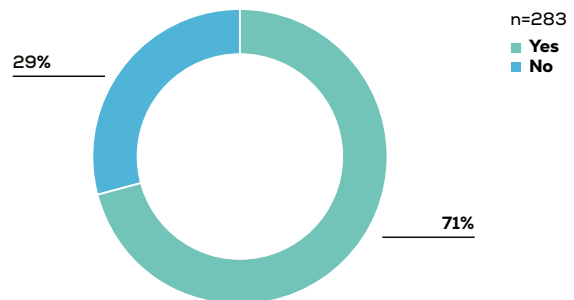

Do you know why Everllence's TURBAIR® vacuum blower systems provide an eco-friendly alternative to water ring pumps?

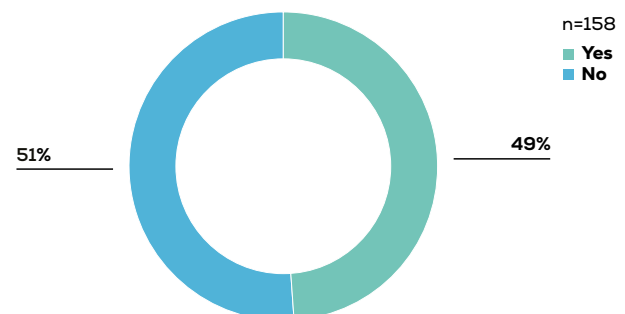

What do you think the absorbed energy savings of TURBAIR® vacuum systems are in comparison to water ring pumps?

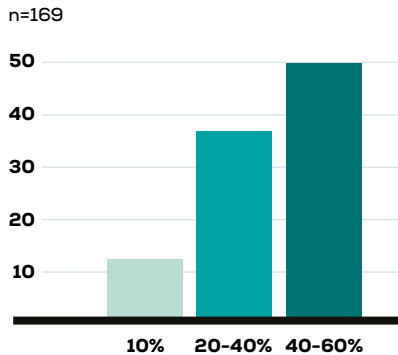

How much is the energy potential by using a heat exchanger in the exhaust pipe of our Everllence TURBAIR® vacuum systems?

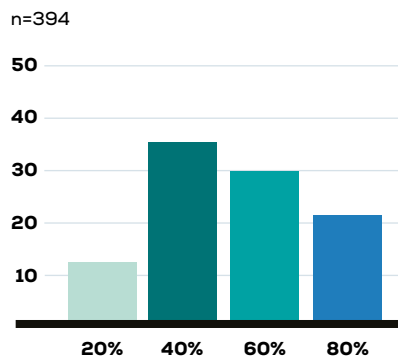

How much water can be saved by using Everllence TURBAIR® vacuum systems?

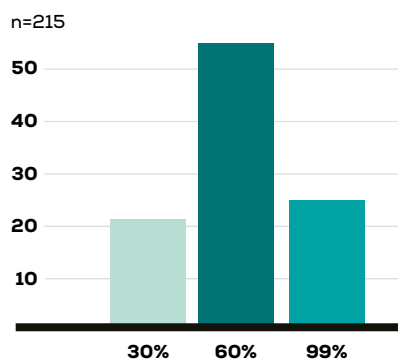

Conclusion: rethinking efficiency in paper manufacturing

TURBAIR® vacuum blower systems offer an effective response to the paper industry's environmental and economic challenges. With its proven performance, the technology supports decarbonization goals, minimizes resource consumption, and improves overall process efficiency.

As demonstrated by Smurfit-Kappa's implementation in Mexico, the transition to advanced vacuum technologies like TURBAIR® is not only possible – it's already underway. Everllence is proud to lead this evolution, helping manufacturers rethink what's possible in sustainable paper production.

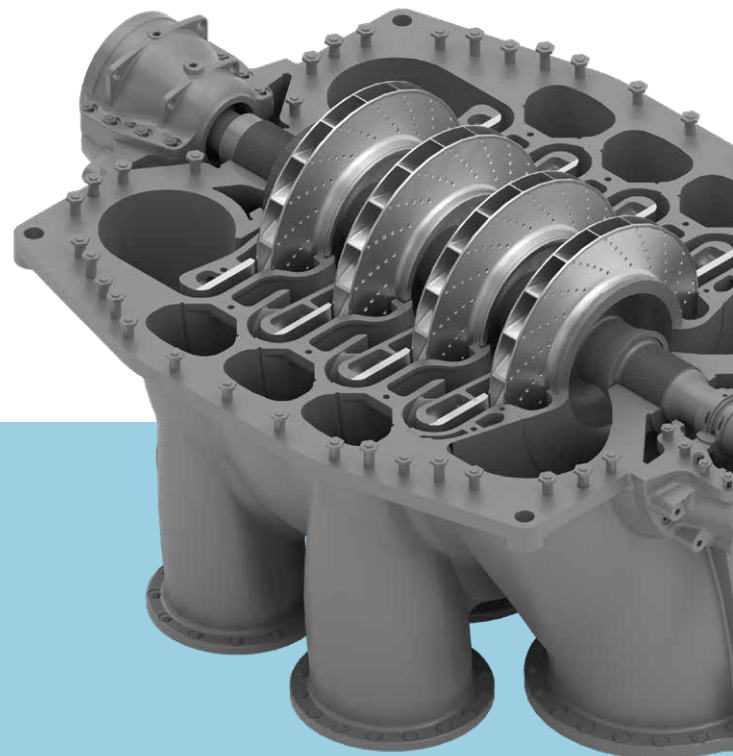

Everllence

Everllence
TURBAIR® Vacuum Systems
8005 Zürich, Switzerland
P +41 44 278-2211
info-ZUR@everllence.com
www.everllence.com

MAN Energy Solutions SE has been renamed to Everllence SE and its products are being rebranded from "MAN" and/or "MAN Energy Solutions" to "Everllence". As this is an ongoing process, any reference to "MAN" and/or "MAN Energy Solutions" is actually a reference to "Everllence".

All data provided in this document is non-binding. This data serves informational purposes only and is not guaranteed in any way. Depending on the subsequent specific individual projects, the relevant data may be subject to changes and will be assessed and determined individually for each project. This will depend on the particular characteristics of each individual project, especially specific site and operational conditions.

Copyright © Everllence. EVR 000278EN-250600, GKM-AUG